

TENDER No.: IITI(MM)/IDO/1/1A/35/SKM/2026-27

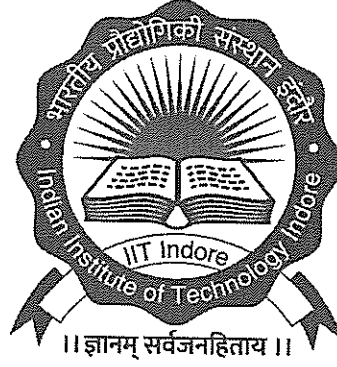

भारतीय प्रौद्योगिकी संस्थान इंदौर  
सिमरोल, खंडवा रोड, इंदौर, पिन- 453552

Indian Institute of Technology Indore  
Simrol, Khandwa Road, Indore- 453552

**Bidding Documents for  
Providing & Fixing of "Architectural Acoustic Retrofitting  
Works at Nalanda Auditorium"**

**Document to be submitted online  
for  
(Technical & Financial Bid as per Schedule of requirement)**

1. 2026-27  
2. 2026-27  
3. 2026-27

**TENDER No.:** IITI(MM)/IDO/1/1A/35/SKM/2026-27



भारतीय प्रौद्योगिकी संस्थान, इंदौर  
सिमरोल, खंडवारोड, भारत,पिन- 453552

Indian Institute of Technology Indore  
Simrol, Khandwa Road, Indore- 453552

**दूरभाष:**91-0731-6603592/3551

**Tel.:** 91-0731-6603592/3551

**Email:** [mms@iiti.ac.in](mailto:mms@iiti.ac.in)

**TENDER DOCUMENT FOR E-PROCUREMENT**

Online Tender is invited by IIT Indore (in Two Bid System) from the respective Original Equipment Manufacturers (OEM) their Authorized Distributors/ Dealers/Firms etc. for Providing & Fixing of "Architectural Acoustic Retrofitting Works at Nalanda Auditorium" at IIT Indore with "PART A" as Technical Bids and "PART B" as Financial Bids.

The details are as follows:

Sl. No.	Name of the Item	NIT No.	EMD
01.	Providing & Fixing of "Architectural Acoustic Retrofitting Works at Nalanda Auditorium"	35	Rs. 70,000/- (Rupees Seventy Thousand Only) Online EMD Submission: Bidder can submit their EMD online by visiting the below link: <a href="https://www.onlinesbi.sbi/sbicollect/collecthome.htm">https://www.onlinesbi.sbi/sbicollect/collecthome.htm</a>

**Note:**

- I. Tender Documents with detailed terms & conditions can be downloaded from websites:  
<https://www.iiti.ac.in/tender> & <https://eprocure.gov.in/eprocure/app>
- II. All the details/documents pertaining to the tender such as tender document, pre-bid report, corrigendum, and any further updates shall be available on IIT Indore website, and Central Public Procurement Portal.
- III. Bids/Quotations may be submitted directly by the OEM or their Authorized distributors/Dealers/Resell Agents/Channel Partners with valid proof of authorization.
- IV. IIT Indore shall not be responsible for non-receipt bid due to internet issues or any other reasons.
- V. All communications with respect to the tender shall be addressed only to:-

**Assistant Registrar,**

**Materials Management Section**

**4th Floor, Abhinandan Bhawan (West Wing),**

**Indian Institute of Technology, Indore**

**Khandwa Road Simrol, Indore- 453552**

**Tel.: 0731660- Ext. 3592/3551**

**Email: [swapnil@iiti.ac.in](mailto:swapnil@iiti.ac.in) /[mms@iiti.ac.in](mailto:mms@iiti.ac.in)**

**Assistant Registrar**

**MM Section, IIT, Indore**

**सहायक कुलसाधिव  
(सामग्री प्रबंधन विभाग)**

**Assistant Registrar  
(Materials Management Section)**

**CONTENTS**

<b>Sl. No.</b>	<b>Contents</b>	<b>Page No.</b>
Chapter- 1	Schedule of Tender	4
Chapter- 2	Instruction to Bidders	5
Chapter- 3	Instructions for Online Bid Submission: <ul style="list-style-type: none"> <li>• Registration</li> <li>• Searching of Tender Documents</li> <li>• Preparation of Bids</li> <li>• Submission of Bids</li> <li>• Assistance to Bidders &amp;</li> <li>• General Instruction to the Bidders</li> </ul>	6-9
Chapter- 4	General Terms and Conditions of Tender	10-17
Chapter- 5	Special Terms and Conditions of Tender	18
Chapter-6	Essential Qualification Criteria	19-20
Chapter- 7	Technical Specification Bid	21-22
Chapter- 8	Financial Bid	23
Form- I	Manufacturer's Authorization & Warranty Support Declaration	24
Form-II	Unpriced Technical Bid	25
Form- III	Declaration For DPIIT Registration	26
Form- IV	Declaration Regarding Clean Track/No Legal Action	27
Form- V	Bidder Information Form	28
Form- VI	Previous Supply Order List Format	29
Form- VII	Acceptance of Tender Terms & Conditions	30-31
Form- VIII	Declaration of Annual Turnover And Income Tax Return	32
Form- IX	Query Format	33
Form- X	Electronic-Performance Security Format	34
Form- XI	Format For Price Breakup/Financial Document	35
Form- XII	Declaration Regarding Sales and Support	36
Form- XIII	Price Reasonability Certificate	37
Form- XIV	Technical Specifications Compliance Sheet	38
Form- XV	Undertaking	39

**CHAPTER- 1  
SCHEDULE OF TENDER**

Sl. No.	Event	Date and Time/ Remarks
01	Commencement of Downloading of Tender Document	<b>June 03, 2026</b> <a href="https://eprocure.gov.in/eprocure/app">https://eprocure.gov.in/eprocure/app</a> and <a href="https://www.iiti.ac.in/tender">https://www.iiti.ac.in/tender</a>
02	Bid Submission Start Date	<b>June 03, 2026</b>
03	Site Visit Duration (Nalanda Auditorium, IIT Indore)	<b>June 03 to 05, 2026</b> <b>Site visit timings - 10:00 am to 05:00 pm.</b>
04	Last date & Time of Submission of Bids Online (Technical and Financial Bid)	<b>June 09, 2026 up till 03:00 PM, (IST)</b> Please refer NIT Documents
05	Date & Time of Opening of Technical Bids	<b>June 10, 2026, at 03:00 PM, (IST)</b> Please refer NIT Documents
06	All communications with respect to the tender shall be addressed to:	<b>Assistant Registrar, MM Section</b> 4th Floor, Abhinandan Bhawan (West Wing), Indian Institute of Technology, Indore Khandwa Road Simrol, Indore- 453552 Tel.: 0731-660 Ext 3592/3551 Email: <a href="mailto:swapnil@iiti.ac.in">swapnil@iiti.ac.in</a> , <a href="mailto:mms@iiti.ac.in">mms@iiti.ac.in</a>
07	For any assistance required	<b>CPP Portal website: <a href="http://www.eprocure.gov.in">www.eprocure.gov.in</a></b> <b>CPP Portal Help Desk Toll-Free No.:</b> <b>18002337315, 180030702232</b>

**# Note:**

- 1) Prospective bidders are advised to submit their doubts/questions/clarifications as per Form-IX only (if any), bearing tender no., title and marked "Queries for Pre-Bid Meeting" through Mail: [swapnil@iiti.ac.in](mailto:swapnil@iiti.ac.in) & [mms@iiti.ac.in](mailto:mms@iiti.ac.in) as per the schedule mentioned above.
- 2) The escalation matrix for all types of queries is as follows:-  
Level-I Senior Assistant, MM Section, ID- [swapnil@iiti.ac.in](mailto:swapnil@iiti.ac.in)  
Level-II Section Officer, MM Section, ID- [somms@iiti.ac.in](mailto:somms@iiti.ac.in)  
Level-III Assistant Registrar, MM Section ID- [armms@iiti.ac.in](mailto:armms@iiti.ac.in)  
Any clarifications must follow the above escalation hierarchy only. Queries must be addressed to the appropriate level as per the matrix.
- 3) All communications from the bidder must originate only from valid email address of bidder organization/firm registered on CPPP. The tender inviting authority reserves the right to disregard any correspondence received from email addresses not from organization/firm registered on CPPP.
- 4) As a condition of participation, bidders may be required to submit a declaration of genuineness on company letterhead, confirming:
  - a. the authenticity of all information provided
  - b. the genuineness of all documents submitted,
  - c. and the validity of all communications made during the tender process.
- 5) Submission of false information, fabricated documents, or use of unverified/inauthentic email addresses shall lead to rejection of the bid at any stage, along with possible legal action.
- 6) If the tender doesn't open on the above-mentioned date, because of any unforeseen circumstances, then the next working day will be considered as the tender-opening date.

  
**Assistant Registrar**  
**MM Section, IIT Indore**

**सहायक कुलसचिव**  
**(सामग्री प्रबंधन विभाग)**  
**Assistant Registrar**  
**(Materials Management Section)**

**CHAPTER-2**  
**INSTRUCTIONS TO THE BIDDERS**

1. The tender shall be submitted in accordance with these instructions and any tender not confirming to the instructions as under is liable to be rejected. These instructions shall form the part of the tender and the contract.
2. For Online Bid Submission as per the directives of Department of Expenditure, this tender document has been published on the Central Public Procurement Portal ([URL:http://eprocure.gov.in/eprocure/app](http://eprocure.gov.in/eprocure/app)). The bidders are requested to submit the copies of their bids electronically (digitally) on CPP Portal, using valid Digital Signature Certificates. More useful information regarding submission of the online bids is available/obtained at [URL:http://eprocure.gov.in/eprocure/app](http://eprocure.gov.in/eprocure/app) on the CPP Portal.
3. The Bidders are requested to read and tender document carefully and ensure all the compliance with instructions herein. Non-Compliance of the instructions contained in this document may disqualify the bidders from the tender process.
4. **For Registration:** Bidders are required to enroll on the e-Procurement module of the Central Public Procurement Portal ([URL:http://eprocure.gov.in/eprocure/app](http://eprocure.gov.in/eprocure/app) by clicking on the link "**Click here to Enroll**". Enrolment on the CPP Portal is free of charge.
5. Foreign Bidders have to refer "DSC details for foreign Bidders" for Digital signature Certificates requirements which comes under Download Tab at <http://eprocure.gov.in/eprocure/app?page=Standard Bidding Documents &service=page> and the remaining part is same as above and below.
6. While submitting the tender, if any of the prescribed conditions are not fulfilled or are incomplete in any form, the tender is liable to be rejected. If any tenderer stipulate any condition of his own, such conditional tender is liable to be rejected.
7. IIT Indore reserves the right to reject any tender/bid wholly or partly without assigning any reason/justification to any.
8. The Technical Evaluation Committee constituted by the IIT Indore shall have the right to verify the particulars furnished by the bidder independently.
9. Tenderer shall take into account all costs including Cartage, Freight, Installation/fixing, Commissioning, Testing and Training etc. of material at site i.e. IIT Indore before quoting the rates. In this regard no claim for any extra payment/work for any reason shall be entertained.
10. The item should be delivered at IIT Indore, Khandwa Road, Simrol, Indore PIN 453552 and the supplier shall be responsible for any damage/casualty during the transit of goods.
11. All the tender documents & price bid to be uploaded as per this tender are to be digitally signed by the bidder.
12. Interested bonafide and reputed manufacturers/Indian agents (on behalf of their foreign principals) may submit online bids for each of the above furniture along with all requisite documents and scanned copy of online EMD submission reference.
13. The Bidder(s) may note that ONLINE BIDS will ONLY be accepted. All the requisite supporting documents mentioned in the bid document must be uploaded On-line <http://eprocure.gov.in/eprocure/app>. **The Bids sent through FAX, E-mail, by hand and/or by any post/courier shall not be accepted/ processed, in any case.**
14. The bidders may submit duly filled and completed bidding document ONLINE as per instructions contained in the bidding documents Incomplete bid shall be liable to be rejected. The conditions of tender shall be governed by the details contained in complete bid document.
15. In case, holiday is declared by the Government on the day of opening the bids, the bids will be opened on the next working day at the same time. The IIT Indore reserves the right to accept or reject any or all the bids at any stage.
16. The detailed instruction for online submissions of bid(s) through e-procurement module of Central Public Procurement of NIC, the bidder(s) may visit following link:- <http://eprocure.gov.in>

**CHAPTER - 3**  
**INSTRUCTIONS FOR ONLINE BID SUBMISSION**

The bidders are required to submit soft copies of their bids electronically on the CPP Portal, using valid Digital Signature Certificates. The instructions given below are meant to assist the bidders in registering on the CPP Portal, prepare their bids in accordance with the requirements and submitting their bids online on the CPP Portal.

More information useful for submitting online bids on the CPP Portal may be obtained at: <https://eprocure.gov.in/eprocure/app>.

**REGISTRATION**

- 1) Bidders are required to enroll on the e-Procurement module of the Central Public Procurement Portal (URL: <https://eprocure.gov.in/eprocure/app>) by clicking on the link "Online bidder Enrollment" on the CPP Portal which is free of charge.
- 2) As a part of the enrolment process, the bidders will be required to choose a unique username and assign a password for their accounts.
- 3) Bidders are advised to register their valid email address and mobile numbers as part of the registration process. These would be used for any communication from the CPP Portal.
- 4) Upon enrolment, the bidders will be required to register their valid Digital Signature Certificate (Class III Certificates with signing key usage) issued by any Certifying Authority recognized by CCA India (e.g. Sify / nCode / eMudhra etc.), with their profile.
- 5) Only one valid DSC should be registered by a bidder. Please note that the bidders are responsible to ensure that they do not lend their DSC's to others which may lead to misuse.
- 6) Bidder then logs in to the site through the secured log-in by entering their user ID / password and the password of the DSC / e-Token.

**SEARCHING FOR TENDER DOCUMENTS**

- 7) There are various search options built in the CPP Portal, to facilitate bidders to search active tenders by several parameters. These parameters could include Tender ID, Organization Name, Location, Date, Value, etc. There is also an option of advanced search for tenders, wherein the bidders may combine a number of search parameters such as Organization Name, Form of Contract, Location, Date, Other keywords etc. to search for a tender published on the CPP Portal.
- 8) Once the bidders have selected the tenders they are interested in, they may download the required documents / tender schedules. These tenders can be moved to the respective 'My Tenders' folder. This would enable the CPP Portal to intimate the bidders through SMS / email in case there is any corrigendum issued to the tender document.
- 9) The bidder should make a note of the unique Tender ID assigned to each tender, in case they want to obtain any clarification / help from the Helpdesk.

**PREPARATION OF BIDS**

- 1) Bidder should take into account any corrigendum/prebid report published on the tender document before submitting their bids.
- 2) Please go through the tender advertisement and the tender document carefully to understand the documents required to be submitted as part of the bid. Please note the number of covers in which the bid documents have to be submitted, the number of documents - including the names and content of each of the document that need to be submitted. Any deviations from these may lead to rejection of the bid.
- 3) Bidder, in advance, should get ready the bid documents to be submitted as indicated in the tender document / schedule and generally, they can be in PDF / XLS / RAR / DWF/JPG formats. Bid documents may be scanned with 100 dpi with black and white option which helps in reducing size of the scanned document.
- 4) To avoid the time and effort required in uploading the same set of standard documents which are required to be submitted as a part of every bid, a provision of uploading such standard documents (e.g. PAN card copy, annual reports, auditor valid certificates etc.) has been provided to the bidders. Bidders can use "My Space" or "Other Important Documents" area available to them to upload such documents. These documents may be directly submitted from the "My Space" area while submitting a bid, and need not be uploaded again and again. This will lead to a reduction in the time required for bid submission process.

**Note:** My Documents space is only a repository given to the Bidders to ease the uploading process. If Bidder has uploaded his Documents in My Documents space, this does not automatically ensure these Documents being part of Technical Bid.

**SUBMISSION OF BIDS**

- 1) Bidder should log into the site well in advance for bid submission so that they can upload the bid in time i.e. on or before the bid submission time. Bidder will be responsible for any delay due to other issues.
- 2) The bidder has to digitally sign and upload the required bid documents one by one as indicated in the tender document.
- 3) Bidders are requested to note that they should necessarily submit their financial bids in the format provided and no other format is acceptable. If the price bid has been given as a standard BoQ format with the tender document, then the same is to be downloaded and to be filled by all the bidders. Bidders are required to download the BoQ file, open it and complete the white colored (unprotected) cells with their respective financial quotes and other details (such as name of the bidder). No other cells should be changed. Once the details have been completed, the bidder should save it and submit it online, without changing the filename. If the BoQ file is found to be modified by the bidder, the bid will be liable to be rejected. **The vendor/firm should fill the complete details as mentioned in BOQ and exclusion of any cell of BOQ (Financial bid), the cost will be treated as inclusive of GST and other charges as mentioned in the BOQ column.**
- 4) The server time (which is displayed on the bidders' dashboard) will be considered as the standard time for referencing the deadlines for submission of the bids by the bidders, opening of bids etc. The bidders should follow this time during bid submission.
- 5) All the documents being submitted by the bidders would be encrypted using PKI encryption techniques to ensure the secrecy of the data. The data entered cannot be viewed by unauthorized persons until the time of bid opening. The confidentiality of the bids is maintained using the secured Socket Layer 128 bit encryption technology. Data storage encryption of sensitive fields is done. Any bid document that is uploaded to the server is subjected to symmetric encryption using a system generated symmetric key. Further this key is subjected to asymmetric encryption using buyers/bid opener's public keys. Overall, the uploaded tender documents become readable only after the tender opening by the authorized bid openers.
- 6) The uploaded tender documents become readable only after the tender opening by the authorized bid openers.
- 7) Upon the successful and timely submission of bids (i.e. after Clicking "Freeze Bid Submission" in the portal), the portal will give a successful bid submission message & a bid summary will be displayed with the bid no. and the date & time of submission of the bid with all other relevant details.
- 8) The bid summary has to be printed and kept as an acknowledgement of the submission of the bid. This acknowledgement may be used as an entry pass for any bid opening meetings.

**ASSISTANCE TO BIDDERS**

1. Any queries relating to the tender document and the terms and conditions contained therein should be addressed to the Tender Inviting Authority for a tender or the relevant contact person indicated in the tender.
2. Any queries relating to the process of online bid submission or queries relating to CPP Portal in general may be directed to the 24x7 CPP Portal Helpdesk.

**GENERAL INSTRUCTIONS TO THE BIDDERS**

- 1) The tenders will be received online through portal <http://eprocure.gov.in/eprocure/app>. In the Technical Bids, the bidders are required to upload all the documents in pdf format.
- 2) Possession of a Valid Class II/III Digital Signature Certificate (DSC) in the form of smart card/e-token in the company's name is a prerequisite for registration and participating in the bid submission activities through <https://eprocure.gov.in/eprocure/app>. Digital Signature Certificates can be obtained from the authorized certifying agencies, details of which are available in the web site <https://eprocure.gov.in/eprocure/app> under the link "Information about DSC".
- 3) Tenderer are advised to follow the instructions provided in the "Instructions to the Tenderer" for the e-submission of the bids online through the Central Public Procurement Portal for e-Procurement at <http://eprocure.gov.in/eprocure/app>

**Online Bid Form**

The bidder shall complete the online bid form and the appropriate price schedule furnished in the online bidding documents, indicating, inter alia for the goods to be supplied, a brief description of the goods, their country of origin, quantity and prices.

**Online Bid prices**

The Bidder shall indicate on the Price Schedule the unit price and total bid prices of the goods it proposes to supply under the Contract. To this end, the Bidders are allowed the option to submit the online bids for any one or more schedule specified in the "Schedule of Requirement" and to offer discounts for combined schedules. However, Bidders shall quote for the complete requirement of goods and services specified under each schedule on a single responsibility basis, failing

## **TENDER No.: IITI(MM)/IDO/1/1A/35/SKM/2026-27**

which such bids (for the schedule in question) will not be taken into account for evaluation and will not be considered for award.

Prices indicated in the online price schedule shall be entered separately in the following manner.

### **I. For goods offered from within India:**

- a. The price of the goods should be quoted for destination basis, charges towards freight; installation etc. may be mentioned inclusive of GST as applicable after referring the attached GST Notification.
- b. Any sales or other taxes/duties should be clearly mentioned, which will be payable on the goods in India if the contract is awarded.
- c. Charges for inland transportation, insurance and other local costs incidental to delivery of goods to their final destination should be mentioned.
- d. Any element of cost, taxes, duties levies etc. not specifically indicated in the online bid, shall not be paid by the purchaser. **If GST amount is not quoted in the BOQ (Financial Bid), the total cost will be treated as inclusive of GST. No further communication will be entertained later or else the EMD will be forfeited.**

### **II. For goods offered from abroad**

- a. **The price of goods shall be quoted in Ex-Works/FOB/FCA/CIP/CIF/FORD and the same should be mentioned in terms & conditions of the firm.**
- b. Charges for inland transportation, insurance and other local costs incidental to delivery of the goods from the port of entry in India to their final destination should be specified.
- c. The terms FOB, CIF, CIP etc. shall be governed by the rules and regulations prescribed in the current edition of INCOTERMS, published by the Chamber of Commerce, Paris.
- d. Prices quoted by the bidder shall remain firm and fixed during the currency of the contract and not subject to variation on any account, unless otherwise specified in the Schedule of Requirements.

### **III. Bid currencies**

- a. For domestic goods prices shall be quoted in Indian rupees only. Commission for Indian Agent, if payable, shall also be quoted in Indian Rupees only.
- b. For imported goods prices shall be quoted either in Indian rupees or may be quoted in foreign currency and the portion of the allied work and services, which are to be undertaken in India (like supply and installation of Furniture), are to be quoted in Indian currency.

### **IV. Indian Agent**

If a foreign bidder has engaged an agent in India in connection with its online bid it will be required to give the following information in the online bid:

- i) Name and Address of the Indian agent with their permanent income tax number.
- ii) Details of the services the agent will render
- iii) Agency commission shall be indicated in the space provided for in the price schedule and will be paid to the bidder's agent in Indian rupees.

### **VI. Period of validity of online bids: Online Bids shall remain valid for acceptance for 180 days after the date of bid submission.**

**Note –** Non-compliance of the above mentioned points may disqualify your offer for further consideration.

**ADVISORY ON FRAUD CALLS/MESSAGE MADE IN THE  
NAME OF IIT INDORE**

- (a) This is to inform you that no officials from the IIT Indore make any telephone calls/messages/emails/whatsapp seeking personal or irrelevant information from the bidder. In case any additional documentation is required from bidder, it is sought only through the official email(s) originating from the institute domain name i.e. **@iiti.ac.in**.
- (b) **No tender/application/documentation fee is applicable** for any type of the tenders being floated by this institute.
- (c) The IIT Indore hereby advises all the bidders to refrain from entertaining any suspicious telephone calls /messages/emails/whatsapp made in the name of IIT Indore asking for money on behalf of the institute. **They are also advised not to reveal any personal information or transfer any money in response to such calls/messages/emails/whatsapp.**
- (d) Moreover, they should bring such matters to the notice of the institute viz email to **mms@iiti.ac.in**.
- (e) In case any bidder responds and becomes pray to any such fraudulent communication the responsibility shall not lie with this institute.

**CHAPTER- 4**  
**GENERAL TERMS AND CONDITIONS**

1. **Bidder:** Tenders are invited only from **Original Equipment Manufacturers** OR their **Authorized Distributors/ Dealers/Firms etc.**, Vendors are requested to **attach valid proof** to show that they are the Authorized Dealers of the brand that they are quoting for the manufacturers of the product. Bids/Quotations of the internationally recognized brand from authorized dealers only will be accepted.
2. **Tender Type: Two- Bid through Online Mode.**
  - (a) **Technical Bid:** Technical bid will be opened on the due date for technical evaluation of bids. The technical evaluation matrix will be uploaded on CPP Portal for intimation to the firms. The technically disqualified firms can represent disqualification within a week of uploading of technical evaluation matrix on CPP Portal. **Non-representation within the stipulated time the tender will be processed further and no representation will be accepted thereafter.**
  - (b) **Financial Bid:** The financial bids of technical qualified responsive bidders will be opened.
3. **Confidentiality:** Information relating to the examination, evaluation, comparison, and post qualification of bids, and recommendation of contract award, shall not be disclosed to bidders or any other persons not officially concerned with such process until publication of the Contract Award.  
Any effort by a Bidder to influence the Purchaser in the examination, evaluation, comparison, and post qualification of the bids or contract award decisions may result in the rejection of its Bid.
4. **Pre-Bid Meeting (If required) and clarifications:** Pre-Bid meeting specified as mentioned date and time in Time Schedule of this document. The purpose of the meeting is to answer the queries of the prospective bidders on the technical bid and commercial terms and conditions of this tender.
  - i. **Submission of Pre-Bid Queries:** In view of the above, prospective bidders may submit their doubts/questions/clarifications, if any, strictly as **Form-IX**, clearly mentioning the tender number and title, and marking the mail subject as "Queries for Pre-Bid Meeting". Queries shall be submitted only through email to [swapnil@iiti.ac.in](mailto:swapnil@iiti.ac.in) and [mms@iiti.ac.in](mailto:mms@iiti.ac.in) as per the schedule mentioned above in the chapter-1.
  - ii. Clarifications sought by the bidders are to be mandatorily submitted in the IITI provided format only. Pre-Bid queries submitted in any other format (including informal letters, from generic, unverified, or third-party emails) will not be considered and summarily rejected.
  - iii. **Addressing on Queries:-**
    - a. All tender-related queries must be addressed only to the officials listed in the escalation matrix.
    - b. To ensure timely and effective responses, we request that all communications be sent only through the designated channels. Messages sent to unrelated offices or outside the defined process may not be considered.
5. **Bid Submission:** Bidders are requested to submit the bids after the issue of minutes of the pre-bid meeting duly considering the changes made if any, during the pre-bid meeting. Bidders are totally responsible for incorporating/complying with the changes/amendments issued if any during pre-bid meetings in their bid. All the two parts of the bid shall be submitted online on <http://eprocure.gov.in/eprocure/app>. **The Bids sent through FAX, E-mail, by hand and/or by any post/courier shall not be accepted/ processed, in any case.**
6. **Late Bids:** IIT Indore shall not be responsible for non-receipt bid due to internet issues or any other reasons.

**TENDER No.: IIT(MM)/IDO/1/1A/35/SKM/2026-27**

7. **Bid Validity:** The bids shall be valid for a period of **180 days** from the date of opening of the tenders.
8. **Modification and withdrawal of bids:** No bid can be modified subsequent to the deadline for submission of bids. No bid can be withdrawn after the deadline for submission of bids and the expiration of the period of bid validity.
9. **Opening of Tenders:** The decryption of the bids would be done as specified schedule mentioned in the tender document on the Central Public Procurement Portal. In the event of the specified date of Bid opening being declared a holiday for the IIT, Indore the Bids shall be opened at the appointed time and location on the next working day. In two-parts bidding, the financial bid shall be opened only for those who qualified in the technical evaluation stage by the committee.
- a) **Bid Security (EMD):** Earnest Money Deposit (EMD / Bid Security (BS) has to be submitted by bidders except those who are registered with:-  
(i) **Micro and Small Enterprises (MSEs)**  
(ii) **Central Purchase Organization (CPO)**  
(iii) **Concerned Ministry / Department.**  
(iv) **Startups as recognized by the Department of Industrial Policy & Promotion (DIPP).**
- b) In such case, a copy of the valid certificate showing registration with the abovementioned institutions to be uploaded in Cover-I of the e-tender in PDF format.
- c) In case the unit is not covered as above, the EMD should be submitted online via <https://www.onlinesbi.sbi/sbicollect/collecthome.htm> and the payment reference should be attached in PDF with Cover I.
- d) The EMD will be returned to the unsuccessful bidders after the order (s) are placed with the successful technically qualified L-1 bidder.
- e) The EMD will be forfeited if the technically qualified L-1 bidder fails to accept the order based on his/her offer/bid or fails to supply the items.
- f) No interest will be payable by the Purchaser on the Earnest Money Deposit. **The earnest money of all the unsuccessful tenderers will be returned to them after the finalization of order or immediately after the completion of the validity of the bid.** The Earnest Money of the successful bidder shall be returned on receipt of Performance Security. If the successful bidder fails to furnish the performance security or fails to supply the item as per Purchase Order (PO) terms and conditions within the stipulated period, the earnest money shall be liable to be forfeited by IIT Indore.

**10. BANK DETAILS:**

Account Name : Registrar IIT Indore  
Account No. : 36948979864  
IFSC Code : SBIN0030524  
Bank Name : State Bank of India  
Branch Address : Simrol Branch, District- Indore (M.P.)

11. **Preliminary Examination:** The technical evaluation committee shall examine the bids to confirm that all documents and technical documentation requested in Chapter-6 & 7 have been provided, and to determine the completeness of each document submitted. If any of these documents or information is missing, the offer shall be liable to be rejected.
- (a) Technical Bid and Price Bid,  
(b) All the tenders received will first be scrutinized to see whether the tenders meet the basic requirements as incorporated in the tender enquiry document. The tenders, who do not meet the basic requirements, are to be treated as unresponsive and shall be ignored.

**TENDER No.: IITI(MM)/IDO/1/1A/35/SKM/2026-27**

(c) If required, technical committee may invite the bidders for technical demonstration of the quoted item/ as part of the technical evaluation.

12. The financial offer/bid will be opened only for the offer/bid which submits all the required necessary documents and verified by the technical committee as technically qualified bidder as per Tender.
13. **Bid Evaluation Procedure:** For the purpose of selection of the bidder, a two-stage bidding process will be followed.
- The response to the tender should be submitted in two parts viz. Technical Bid & Commercial Bid.
  - Evaluation will be done strictly on Essential Qualification and Technical criteria as mentioned chapter 6 & 7. If required, the committee may invite the bidders to demonstrate the specifications, features of the quoted item as part of the technical evaluation.
  - In case of Indigenous, All the bid shall be evaluated on the basis of final landed cost at IITI which includes all taxes duties and other charges. If bidders quote different GST slabs for a product, then IITI will follow HSN code and GST rules of GOI for uniform comparison of all bids.
  - In case of import, the below mentioned calculation will be followed to arrive at the technically qualified lowest responsive bidder:

<u>Sl.No</u>	<u>INCOTERMS</u>	<u>Details of Add on cost</u>
1.	<b>Ex-WORKS</b>	ADD ON 25% of Ex-WORKS PRICE against inland freight, export clearance, air freight, insurance, loading & unloading, custom duty (@5.15% ), custom clearance, stamp duty etc., transportation.
2.	<b>FCA/FOB</b>	ADD ON 20% of FCA/FOB PRICE against export clearance, air freight, insurance, loading & unloading, custom duty (@5.15%), custom clearance, stamp duty etc., transportation.
3.	<b>CIP/CIF</b>	ADD ON 15% of CIP/CIF PRICE against insurance, loading & unloading, custom duty (@5.15%), custom clearance, stamp duty etc., transportation.
4.	<b>FORD IITI</b>	ADD on 5.15% against Custom Duty

- Award Criteria:** The Purchaser reserve the rights to award the contract to the successful Bidder whose bid has been determined to be substantially responsive and has been determined to be the lowest evaluated bid, provided further that the Bidder is determined to be qualified to perform the contract satisfactorily.
- Purchaser's Right to vary Quantities at Time of Award:** The Purchaser reserves the right at the time of Contract award to increase or decrease the quantity of goods and services originally specified in the tender without any change in unit price or other terms and conditions. The Purchaser reserves the right to accept or reject any bid at any stage and to annul the bidding process and reject all bids at any time prior to award of Contract.
- Option Clause:** The Purchaser reserves the right to increase or decrease the quantity of the required goods/items, till final delivery date (or the extended delivery date of the contract), by giving reasonable notice even though the quantity ordered initially has been supplied in full before the last date of the delivery period (or the extended delivery period).
- Fall Clause:** The price quoted by the supplier should not be higher than the maximum retail price, if any, for the stores and the same shall not be higher than the price usually charged by the supplier for stores of the same nature, class or description to any other purchaser. The price charged for the stores supplied under the contract by the supplier shall in no event exceed the lowest price at which the supplier sells the stores of identical description to any other person during the period till performance of all supply orders placed during the currency of the contract is completed.
- Purchaser's right to accept Any Bid and to reject any or All Bids:** The Purchaser reserves the right to accept or reject any bid at any stage and to annul the bidding process and reject all bids at any time prior to award of Contract, without thereby incurring any liability to the affected Bidder or Bidders.

**TENDER No.: IITI(MM)/IDO/1/1A/35/SKM/2026-27**

- x. **Notification of Award:** Prior to the expiration of the period of bid validity, the Purchaser will notify the successful bidder in writing by registered letter or e-mail that the bid has been accepted and a separate purchase order shall follow through post.
- xi. **Signing of Contract:** The IITI shall send the successful Bidder the Purchase Order. Within 05 (Five) days of date of the Purchase Order, the successful Bidder shall sign, date, and return it to the IITI.
- xii. **Order Acceptance:** The successful bidder should submit Order acceptance within 14 days from the date of issue of order/signing of contract, failing which it shall be presumed that the vendor is not interested and his bid security is liable to be forfeited
- xiii. **Delivery:** The date of delivery should be strictly adhered to failing which the purchase/contract order is liable to be cancelled. Penalty may be imposed as per P.O. terms & conditions. Items should be delivered free of cost at **IIT INDORE**
- xiv. **Unloading:** The supplier should ensure to unload all the materials (other related accessories etc.) to the installation site at IIT, Indore. Unloading of the goods at IIT Indore is the responsibility of the supplier. No manpower will be provided by the institute.

**14. Concession/Exemptions:**

**For Import Supplies –** As per Govt. of India Notification No. 51/96 Custom dtd. 23rd July 1996, (Substituted under Notification No.43/2017 dtd.30th June 2017) Concessional Custom Duty is applicable to IITI for all purchases which are essential for research. We shall provide all the documents under this notification to enable you to clear the goods. Please state clearly that this certificate is required. The supplier shall pay and bear all other liabilities, taxes and duties not specifically agreed by the Purchaser in the contract. The Custom Duty Exemption Certificate will not be provided if quoted in Indian currency.

**15. Conflict of Interest among Bidders/Agent:** The bidder found to have a conflict of interest shall be disqualified. A bidder may be considered to have a conflict of interest with one or more parties in this bidding process, if:

- a. they have controlling partner (s) in common; or
- b. they receive or have received any direct or indirect subsidy/financial stake from any of them; or
- c. they have the same legal representative/agent for purposes of this bid; or
- d. they have relationship with each other, directly or through common third parties, that puts them in a position to have access to information about or influence on the bid of another bidder; or
- e. bidder participates in more than one bid in this bidding process. Participation by a bidder in more than one Bid will result in the disqualification of all bids in which the parties are involved. However, this does not limit the inclusion of the components/subassembly/assemblies from one bidding manufacturer in more than one bid.
- f. in cases of agents quoting in offshore procurements, on behalf of their principal manufacturers, one agent cannot represent two manufacturers or quote on their behalf in a particular tender enquiry. One manufacturer can also authorize only one agent/dealer. There can be only one bid from the following:
  - i. The principal manufacturer directly or through one Indian agent on his behalf; and
  - ii. Indian/foreign agent on behalf of only one principal.
- g. Bidder or any of its affiliates participated as a consultant in the preparation of the design or technical specifications of the contract that is the subject of the Bid.
- h. in case of a holding company having more than one independently manufacturing units, or more than one unit having common business ownership/management, only one unit should quote. Similar restrictions would apply to closely related sister companies. Bidders must proactively declare such sister/common business/management units in same/similar line of business

**16. Guarantee/ Warranty:** The quoted items should be covered comprehensive on-site warranty against any manufacturing defect. Warranty certificate should be submitted with the bill(s).

- a) Any deviation in the material and the specifications from the accepted terms may liable to be rejected and the bidders need to supply all the goods in the specified form to the satisfaction / specifications specified in the order / contract and demonstrate at their own cost. The payments shall be made only after receiving the material in the required specifications and quality to the satisfaction of the Institute authorities.

**TENDER No.: IITI(MM)/IDO/1/1A/35/SKM/2026-27**

- b) Upon receipt of notice for defective material, the firm shall within 15 days of receipt of the notice, replace the defective material, free of cost at the destination. No claim whatsoever shall lie on IIT Indore for the replaced goods, thereafter. If the firm fails to replace the defective goods within a reasonable period, IIT Indore may proceed to take such remedial action as may be necessary, at the company's risk and cost.
17. **Insurance:** Wherever necessary, the goods supplied under the contract, shall be fully insured in a freely convertible currency against loss or damage incidental to manufacture or acquisition, transportation, storage and delivery in the manner specified in the contract. If considered necessary, insurance may cover "all risks" including war risks and strike clauses. The amount to be covered under insurance should be sufficient to take care of the overall expenditure to be incurred by the Procuring Entity for receiving the goods at the destination.
18. **Shipping, Packaging and Labeling:** All Material purchased hereunder must be packed and packaged to ensure its safe delivery in accordance with good commercial practices and where incorporated, the IIT, Indore packaging specification. The Supplier shall provide such packing of the Goods as is required to prevent their damage or deterioration during transit to their final destination. The packing shall be sufficient to withstand, without limitation, rough handling during transit and exposure to extreme temperatures, during transit and open storage. Packing case size and weights shall take into consideration, where appropriate, the remoteness of the goods' final destination and the absence of heavy handling facilities at all points in transit, including the final destination. The packing, marking and documentation within and outside the packages shall comply strictly with such special requirements as shall be provided for in the Contract including additional requirements, if any, specified in the contract and in any subsequent instructions ordered by the Purchaser. It is the sole responsibility of the vendor to provide/replace the item/goods, if it is lost or broken during the shipping or transportation due to whatever may be the reason. The date of delivery should be strictly adhered to failing which the purchase order is liable to be cancelled. Penalty may be imposed as per P.O. terms & conditions. Goods should be securely, safely and adequately packed & dispatched and delivered at the risk of supplier. In case of damage consignment the same should be replaced without any cost to the Buyer and the supplier can collect the damaged consignment after satisfactory replacement.
19. **Inspection:** The Purchaser or its representative shall have the right to inspect and/or to test the Goods to confirm their conformity to the Contract specifications at no extra cost to the Purchaser. The inspections and tests may be conducted on the premises of the Supplier or its subcontractor(s), at point of delivery and/or at the Goods final destination. If conducted on the premises of the Supplier or its subcontractor(s), all reasonable facilities and assistance, including access to drawings and production data shall be furnished to the inspectors at no charge to the Purchaser. Should any inspected or tested Goods fail to conform to the specifications, the Purchaser may reject the goods and the Supplier shall either replace the rejected Goods or make alterations necessary to meet specification requirements free of cost to the Purchaser. The Purchaser's right to inspect, test and, where necessary, reject the Goods after the Goods' arrival at Project Site shall in no way be limited or waived by reason of the Goods having previously been inspected, tested and passed by the Purchaser or its representative prior to the Goods shipment. \
20. **Right of Acceptance:** This Institute does not pledge itself and reserves to itself the right of accepting the whole or any part of the tender or portion of the quantity offered and the firm shall supply the same at the rate quoted. The firm shall be at liberty to tender for the whole or any portion or to state in the tender that the rate quoted shall apply only if the entire quantity is taken from the firm.
21. **Patent Rights:** The supplier shall, at all times, indemnify and keep indemnified the purchaser, free of cost, against all claims which may arise in respect of goods & services to be provided by the supplier under the contract for infringement of any intellectual property rights or any other right protected by patent, registration of designs or trademarks. In the event of any such claim in respect of alleged breach of patent, registered designs, trademarks etc. being made against the purchaser, the purchaser shall notify the supplier of the same and the supplier shall, at his own expenses take care of the same for settlement without any liability to the purchaser.
22. **Subletting of Work:** The firm shall not assign or sublet the work/job or any part of it to any other person or party. The tender is not transferable. Only one tender shall be submitted by one tenderer.

**TENDER No.: IIT(MM)/IDO/1/1A/35/SKM/2026-27**

23. **No correspondence/discussion/visits whatsoever will be entertained on the subject unless specifically called by this office after opening the tenders for technical discussions/ price negotiations. Any violation of this will render the quotations invalid and the firm is liable to be blacklisted.**
24. **FURNISHING FRAUDULENT INFORMATION/ DOCUMENT-** If it is found that a bidder has furnished fraudulent document/information, the bid security/performance security (wherever applicable) shall be forfeited and the bidder/vendor will be debarred for a period of 3 (three) years from date of detection of such fraudulent act, besides the legal action. In case of major and serious fraud, period of debarment may be enhanced.
25. IIT Indore reserves the right to call for techno-commercial/price negotiations. The company should depute a competent representative for such discussion/negotiations whenever called for and he shall be competent to make on-the-spot decisions.
26. IIT Indore does not bind itself to accept the lowest or any tender and may cancel/withdrawal the tender without assigning any reason and no claim whatsoever, for any reason arising out of such action, will be entertained by IIT Indore.
27. IIT Indore is a green zone campus, hence, after delivery and acceptance of item suppliers should take back the waste packing material such as plastic, wrapping paper, and toxic material. Further, any wooden packing material is to be handed over to the store.
28. **Force Majeure:** Neither the contractor nor the institute shall be liable to the other, for any delay in or failure of their respective obligations under this control caused by occurrences beyond the control of either party because of fire, floods, acts of God, acts of public enemy, wars, riots, strikes, lockouts, sabotage, fire, floods, explosion, epidemic, quarantine restrictions, any law statute or ordinance order actions or regulations of the Government or any compliance there is similar to the above. Either party shall promptly notify the other of his commencement and cessation of such contingency and prove that such is beyond the controls and effects the implementation of this contract adversely.
29. The firm may give any of their commercial terms, if required, in their techno-commercial offer only, and price quotation should contain only the price.
30. Please inform the IIT Indore in writing whether the owner of the firm or any of their partners/employees has close relations working with IIT Indore. This is for record only.
31. IIT Indore **reserves the right to modify/alter/insertion or deletion on any part of the tender document to ensure fulfillment of its material & service requirement at any stage.**
32. The instructions about bidding given in this advertisement and the Tender Documents should be read thoroughly before bidding. IIT Indore reserves the right to accept or reject any or all quotations at any stage without assigning any reason whatsoever it may be.
33. **Breach of Terms and Conditions:** IIT- Indore reserves the right to accept or reject or cancel any or all inquiries or quotations at any stage without assigning any reason thereof. In case of cancellation of order due to Non-compliance of with Terms and Conditions and Breach of the Contract, No compensation will be paid towards the progress of order/procurement.
34. **Governing Law:** The order placed will be a contract between the supplier and the buyer and shall be governed by the LAWS of India and under the contract shall be taken by the parties only in Indore, India to competent jurisdiction. All Domestic and International disputes are subject to Indore jurisdiction only.

**Benefits to Micro and Small Enterprises (MSEs)/Start-Up:**

With reference to the Order of the Ministry of MSME , under the Public Procurement Policy March 2012 , Micro and Small Enterprises shall be entitled for benefits, subject to terms and conditions, as under:

**a) *Qualifying Criteria for MSEs , SC/ST vendors :***

- i. MSE bidders must submit registration certificates from any of the following (or any other body specified by the Ministry of MSME) :**
  - National Small Industries Corporation (NSIC)
  - District Industries Centres (DIC)
  - Coir Board
  - Khadi and Village Industries Commission (KVIC)
  - Khadi and Village Industries Board (KVIB)
  - Directorate of Handicrafts and Handloom
  - Adhar Udyog Memorandum
- ii. SC/ST owned enterprises (i.e. SC/ST proprietorship, or holding minimum 51% shares in case of Partnership/ Private Limited Companies) shall additionally submit relevant SC/ST certificates issued by any of the following:**
  - District/Additional District Magistrate /Collector/Deputy Commissioner/ Additional Deputy Commissioner/Deputy Collector/1<sup>st</sup> Class Stipendiary Magistrate/Sub-divisional Magistrate /
  - Taluka Magistrate / Executive Magistrate/ Extra Assistant Commissioner
  - Chief Presidency magistrate /Additional Chief Presidency magistrate /Presidency magistrate
  - Revenue Officer not below the rank of Tehsildar
  - Sub-divisional Officer of the area where the individual and/or his family normally resides
- iii. The registration shall be valid as on date of placement of order. A self- attested photocopy of the relevant certificate shall be submitted as a support document.**
- iv. The registration must be for the items/category of items /services relevant to the tendered items/category of items/services.**
- v. If the bidder is a MSME, it shall declare in the bid document the Udyog Adhar Memorandum Number issue to it under MSMED Act, 2006. If a MSME bidder do not furnish the UAM Number along with bid documents, such MSME unit will not be eligible for the benefits available under Public Procurement Policy for MSEs order 2012.”**
- vi. The benefit as above to MSEs shall be available only for Goods produced and services rendered by MSEs. However, trader/sellers/distributors/authorized agents will not be considered for availing benefits under PP Policy 2012 for MSEs as per MSE guidelines issued by MoMSME.**

**b) *Purchase Preference for MSE :***

- i. Price quotation in tenders: In tender, participating Micro and Small Enterprises, quoting price within price band of L1+15 percent shall also be allowed to supply a portion of requirement by bringing down their price to L1 price in a situation where L1 price is from someone other than a Micro and Small Enterprise and such MSE shall be allowed to supply up to 25 per cent of total tender value..**
- ii. A share of 4% out of this 25% shall be allowed to be supplied by participating MSEs owned by Scheduled Cast/Scheduled Tribe entrepreneurs. In the case of an SC/ST owned MSE failing to participate in the tender or not meeting the tender requirements, this 4% sub-target shall be met by other participating MSEs.**
- iii. A share of 3% out of this 25% shall be allowed to be supplied by participating MSEs owned by Women Entrepreneur (proprietorship or holding minimum 51% shares in case of Partnership/Private Limited Company).**
- iv. In case that two or more MSEs are within the L1 +15% band, all such MSEs will be offered the opportunity to match the L1 rate and 25% of the order will be shared equally by them.**
- v. Where the MSE is SC/ST owned or Women Entrepreneurs, they shall be exclusively awarded a share of 4% & 3% of the above 25% in addition to equally sharing the balance 18% with other non-SC/ST or Women Entrepreneur MSEs.**

**TENDER No.: IIT(MM)/IDO/1/1A/35/SKM/2026-27**

- vi. In case of more than one SC/ST or Women Entrepreneur MSE matching the L1 price, they shall equally share 4% & 3% of the order, and additionally share the balance 18% with other non-SC/ST & Women Entrepreneur MSE bidders.

**(ii)Startup(s):** relaxation regarding prior turnover and prior experience is applicable only to all startups recognized by Department for Promotion of Industry & Internal Trade (DPIIT) subject to meeting of quality and technical specifications. Startups may be MSMEs or otherwise.. However, they must enclose valid self-attested registration certificate(s) along with the tender to this effect

**CHAPTER- 5**  
**SPECIAL TERMS AND CONDITIONS**

1. **Payment: No advance payment will be made in any case.** Payment will be released through wire transfer/bank RTGS transfer after providing and fixing of the item(s) and if found satisfactory with regard to quality, quantity and specifications ordered. The payment will be released after statutory deductions within 30 days. For the payment, the firm has to submit Supplier's Invoice indicating, inter alia description and specification of the goods, quantity, unit price, total value; challans(s), Manufacturer's guarantee certificate; bank details/cancelled cheque, installation report, performance bank guarantee (if asked) etc. to the Assistant Registrar, MM Section, IIT Indore.
  - a) **In case of indigenous, the payment term may be**
    - (i) 80% of the total cost will be paid against delivery of the goods received in good conditions at IIT Indore and accepted by the user department.
    - (ii) 20% of the balance of total cost will be paid after satisfactory Installation/ fixing and testing by the IIT employees and submission of performance bank guarantee.
  - b) **In case of import, the payment term may be**
    - i) 100% through Letter of Credit (LC)/Wire Transfer – 80% payment will be released against dispatch documents by our authorized banker.
    - ii) 20% balance after satisfactory Installation/fixing, Commissioning, Testing & Training of the IIT employees and submission of performance bank guarantee.
2. **Performance Security:** Within Thirty Days (30) days from the date of satisfactory Installation/fixing and testing. The firm must submit performance security of 5% of the total order value from an Indian Scheduled Bank before the release of the final payment and after satisfactory Installation/fixing and testing in the form bank guarantee **valid upto sixty (60) days** beyond the warranty period. No interest will be payable by the Purchaser on the Performance Security deposited. In case the supplier fails to provide satisfactory after-sale service within the warranty period, the Performance Security submitted by the firm is liable to be forfeited.
3. **Demonstration of the Quoted Items:** The IIT Indore reserve the right to ask for a free demonstration of the quoted items after giving reasonable time to the bidder at a pre-determined place acceptable to the purchaser for technical acceptability as per the bidding document specifications, before the opening of the Price Bid.
4. **Pre dispatch-** The firm should arrange the pre-dispatch inspection prior to packing & dispatching of the item if asked by the IIT Indore. The firm should share the entire details of the quoted items with original images, catalog and schematic diagrams before packing. Virtual/Online or physical inspection may be done by the IIT Indore technical committee.
5. Items should be delivered only on working days (Monday to Friday) during office hours only i.e. between 10.00 am to 04.00 pm.
6. **Pre- Installation (if any):** Please also mention the pre-installation requirements for the equipment like ambient temperature, humidity, civil work, weather specifications, power specifications, etc. When items are provided full performance satisfaction should be demonstrated.
7. **Installation/fixing & Commissioning:** Bidder shall be responsible for installation/fixing / demonstration wherever applicable and for after sales service during the warranty period and thereafter as mentioned in the contract. Fixing to be arranged by the supplier free of cost and the same is to be done within 30 days of the arrival of the material at site. **For delayed in delivery or in satisfactory installation/ fixing and testing the liquidated damages will be imposed @ 0.5% (Half Percent) per week subject to a maximum of 10% of the total value of supply order & beyond 10% subject to approval of IIT Indore.**
8. **Liquidated Damages:** -As Time is the essence of an order, the date of delivery should be strictly adhered to, otherwise the delivery in full or in part may not be accepted and penalty for late delivery will be imposed @ 0.5% (Half Percent) per week subject to a maximum of 10% of the total value of supply order & beyond 10% subject to approval of IIT Indore. In case of delay in satisfactory Installation/fixing, Testing, Certification etc. also the same rate of penalty shall be leviable. Non- Delivery of material/service may lead to forfeiture of PBG and debarment of the supplier.
9. **Delivery: Free delivery at IIT Indore in case of indigenous orders.** In case of imported offers standard Incoterms shall be applicable. **The bidders must quote both in EX-WORKS/DAP/FORD value for deciding the mode of shipment in case of Import.**
10. In case material offered requires maintenance after the expiry of the warranty, please indicate the approximate cost of comprehensive and on-call basis maintenance and also the availability of local support or otherwise.
11. Please note clearly that the Bids sent through FAX, E-mail, by hand and/or by any post/courier shall not be accepted/ processed, in any case.

**CHAPTER- 6**  
**Essential Qualification Criteria**

**LIST OF DOCUMENTS TO BE UPLOADED WITH TECHNICAL BID as Annexure- I**

Sl. No.	Details	Supporting Document Should be Submitted
1.	The Bidder should be OEM/Authorized/Distributors/Dealers/Firms etc. and should have the existence of firm for a minimum period of 5 Years.	For OEM:- Valid Certificate of Incorporation/Registration Certificate of the
2.	Bidder should submit a valid Manufacturers Authorization Form specific to this tender.	The authorization letter should be on the Letterhead of the concerned OEM. In case of Authorized/distributor/dealer/agent Copy of the valid authorization, the certificate shall be enclosed. <b>Offer submitted without proper authorization shall be liable to be rejected summarily.</b>
3.	<b>Udyog Adhar Memorandum No. if bidder claim MSEs.</b> Copy of valid PAN card, Copy of valid GST registration certificate	Self-certified copies of documents.
4.	<b>WORK EXPERIENCE:</b> The Vendors / Bidders should have work experience as per the following parameters.  Three similar completed work costing not less than <b>Rs. 5,20,380/-</b> in last 03 (three) years for any Govt./Semi Govt./PSU/Centrally Funded Technical Institutes (CFTI) which includes IITs, IISERs, IIMs, NITs, IIITs, NITTTRs, IISc and IEST), CSIR Institutes, Central Universities and /or DAE Institutes (NISER, TIFR) <p style="text-align: center;">OR</p> Two similar completed work costing not less than <b>Rs. 6,93,840/-</b> in last 03 (three) for any Govt./Semi Govt./PSU/Centrally Funded Technical Institutes (CFTI) which includes IITs, IISERs, IIMs, NITs, IIITs, NITTTRs, IISc and IEST), CSIR Institutes, Central Universities and /or DAE Institutes (NISER, TIFR). <p style="text-align: center;">OR</p> One similar completed work costing not less than <b>Rs. 12,14,220/-</b> in last 03 (three) years for any Govt./Semi Govt./PSU/Centrally Funded Technical Institutes (CFTI) which includes IITs, IISERs, IIMs, NITs, IIITs, NITTTRs, IISc and IEST), CSIR Institutes, Central Universities and /or DAE Institutes (NISER, TIFR).  <b>Note:</b> Similar work means architectural acoustic treatment in auditoriums, convention centers, theatres, educational institutions using proposed acoustic materials.	Work orders and satisfactory completion valid certificates issued by respective buyer organization of the above order in support of experience to be enclosed. <b>Without submission of completion certificate the experience will not be considered.</b>  The valid certificate should be in Letter Head of the concerned government organization with authorized signatory.
5.	Bidder Information	As per enclosed Form-V

**TENDER No.: IITI(MM)/IDO/1/1A/35/SKM/2026-27**

6.	List of other Govt. Departments, Public Sector units and Central Autonomous Bodies for which the bidder is supplying material or having the similar type of contracts and a valid certificate regarding the satisfactory performance of the contract	As per enclosed Form-VI
7.	Bidder Acceptance of Tender Document	As per enclosed Form-VII
8.	The bidder should not have been blacklisted by any Government / Semi Government / Board /Corporations /Autonomous Body/ PSU. An undertaking/declaration in this regard should be closed. If any such matter i.e. of blacklisting /suspension is subjudice, even then the concerned firm shall be technically disqualified. <i>"If any one or more Partner/ Directors of any debarred/blacklisted agency promotes or forms a new contracting firm or a sister-concern firm of the said debarred/blacklisted agency, then it shall also be considered as a debarred /blacklisted firm".</i>	As per enclosed Form-IV
9.	<b>FINANCIAL TURNOVER:</b> The firm should have annual financial turnover more than <b>Rs. 17,34,600/-</b> during the past three financial years namely 2022-23, 2023-24 and 2024-25. and In case of OEM, the Average Annual Turn Over should be <b>Rs. 69,38,400/-</b> during the last three financial years namely 2022-23, 2023-24 and 2024-25.  The Vendors / Bidders should not have incurred any loss during the last 03 (three) years (as of 31st March, 2024).Profit after Tax should be positive for the above mentioned period.	As per enclosed Form-VIII and Attach a separate neatly typed sheet on the letter head of Registered Chartered Accountant OR enclose copies of audited Balance Sheet and Profit & Loss Statement for the previous 4 (four) financial year as specified in bid document and further details if required may be asked from the contractor after opening of technical bids. There is no need to upload entire voluminous balance sheet.
10.	The quoted products should not be under end of sales or end of support in next 05(five) years from the date of submission	(Declaration from OEM/ Authorized Distributors/Dealers/firms should be submitted)
11.	The bidding firm/company must be a single company and no consortium should be allowed.	(Declaration from OEM/ Authorized Distributors/Dealers/firms should be submitted)
12.	<b>CATALOGUE and PHOTOGRAPHS:</b> Firm should submit the item wise catalogue of the offered product along with the technical bid. Make and model no. of item must be mentioned along with detailed specification. Photographs related to material/items should be enclosed and Dimensions of material/item, weight and space requirements should also be submitted in technical offer.	Sealed and signed document
13.	Information Accessibility: Product details and technical specifications of the model should be available to the public on OEM official website for verification.	Sealed and signed document
14.	NIT Forms 01 to 15	It is mandatory to fill all the forms duly sealed and signed by the authority and attach a separate neatly typed sheet wherever is required.

**Note: Non-Compliance with any of the above conditions by the bidders will be tantamount to non-eligibility for which tender has been floated and its bid shall be liable to be rejected summarily.**

**Signature & Seal of Bidder**

**Chapter-7****Technical Specification Bid**

(Bidder should submit compliance matrix along with Technical Bid)

Item details and technical specifications as mentioned below: Providing & Fixing of “Architectural Acoustic Retrofitting Works at Nalanda Auditorium”

SI. NO.	Items Description	Qty (Nos.)	Compliance If Yes/ No	Deviation If Any
A	Providing and fixing customized ultra-lightweight diffusive absorptive acoustic treatment in accordance with approved acoustic drawings and design details (Annexure-I & II). The treatment shall comprise specially designed non-periodic pyramid-shaped acoustic modules fabricated from open-cell melamine acoustic foam. The acoustic modules shall be factory-manufactured from ultra-lightweight melamine foam having a density of 9–11 kg/m <sup>3</sup> and shall be profiled into customized pyramid geometries with varying module widths ranging from 300 mm to 750 mm, including varying depths and spacing patterns as specified in the approved acoustic design. <b>Make:</b> DAC Edge/ Sonex / Soniflex			
i.	Panel Size 1200X300X300MM	40		
ii.	Panel Size 1200X450X300 MM	10		
iii.	Panel Size 1200X600X300 MM	80		
iv	Panel Size 1200X750X300 MM	10		

Ultra-lightweight diffusive absorptive acoustic treatment will be fixed to the front surface of balcony in Nalanda Auditorium. The treatment shall consist entirely of customized non-periodic pyramid shaped melamine acoustic foam modules as per sizes mentioned above. The same is specifically designed to reduce grazing reflections and break continuous curved reflective paths from the balcony fronts. The acoustic foam shall be ultra-lightweight and factory profiled into customized pyramid geometries with varying depth and spacing to achieve controlled sound scattering and broadband absorption. The foam modules shall be directly fixed over the prepared balcony substrate using approved high-strength acoustic adhesive and finished in the existing red-blue colour theme of the Nalanda Auditorium as approved by the client. All joints, edges and terminations shall be neatly aligned, securely fixed and properly finished complete in all respects.

**Attachments:-**

- a) Drawing showing the Diffusive absorptive acoustic panel sizing- **Annexure-I**
- b) Drawing showing the plan of the acoustic treatment- **Annexure-II**

**Special Conditions of Contract:**

- i. The bidder shall have successfully completed similar acoustic treatment works in auditoriums, convention centres, theatres, educational institutions. Completion certificates from the respective clients shall be submitted as proof of experience.
- ii. Material property certificates for all acoustic treatment materials proposed in the work shall be submitted for approval prior to installation.
- iii. All acoustic materials shall comply with applicable fire safety requirements and shall be suitable for use in public and institutional buildings.
- iv. The client reserves the right to seek additional technical documentation, sample materials, or third-party verification reports prior to approval of the proposed acoustic treatment system.
- v. The contractor shall guarantee the acoustic treatment system against defects in materials, workmanship, warping, delamination, sagging, or deterioration for a minimum period of one year from the date of completion.

**Note :**

- I. The bidder should submit his acceptance against each column as YES/NO and if No, the bidder should specify the deviation and same must be verified by the OEM.
- II. Firm should quote separately for each item as per BOQ.
- III. Valid proof of the document in support of the claim to be enclosed with the technical bid.
- IV. The Quantity mentioned above is also indicative and might change in the final order.
- V. Prospective bidders can quote Rate as per Unit and the institute will decide on the final order quantity.

(Signature of the Bidder, with Official Seal)

**CHAPTER- 8**  
**Financial Bid**

**FINANCIAL BID –Schedule of price bid in the form of BOQ format:**

1. The below mentioned Financial Proposal/Commercial bid format is provided as BoQ along with this tender document at <https://eprocure.gov.in/eprocure/app>
2. **Bidders are advised to download this BoQ.xls** as it is and quote their offer/rates in the permitted column and upload the same in the commercial bid.
3. Bidder shall not tamper/modify downloaded price bid template in any manner. In case if the same is found to be tampered/modified in any manner, the tender will be completely liable to be rejected and EMD shall be forfeited.
4. Any element of cost, taxes, duties levies, etc. not specifically indicated in the BOQ, shall not be paid by the purchaser.
5. **If the GST amount is not quoted in the BOQ (Financial Bid), the total cost will be treated as inclusive of GST. No further communication will be entertained later or else the EMD will be forfeited.**
6. The tender shall remain valid for acceptance for **180 days**, from the date of tender opening.

**OTHER CONDITIONS FOR PRICE BIDS**

1. No unilateral revision in price will be admissible.
2. INCOTERMS (in case of imported item) should be clearly mentioned on the bid
3. Rates should be quoted in the accounting units (A/U) mentioned in this tender. Rates must be quoted clearly on the free delivery basis at IIT Indore and the total value is also indicated in words.
4. Any optional indicated in techno-commercial bids must be priced separately.
5. In case spares/accessories are applicable, their list and price should be clearly indicated separately.
6. The price must be stated for each item separately. The percentage of reduction, in the unit price, should also be quoted, should order to that extent be placed with you.

\_\_\_\_\_  
**Yours faithfully**

(Signature of the Tenderer)

Printed Name:

Designation:

Company Seal:

Date:

TENDER No.: IITI(MM)/IDO/1/1A/35/SKM/2026-27

प्रपत्र -1 / FORM-I  
निर्माता का अनुज्ञा और वारंटी समर्थन पत्र

**MANUFACTURER'S AUTHORIZATION & WARRANTY SUPPORT DECLARATION**  
**(ON OEMs Letter head)**

Date: \_\_\_/\_\_\_/2026

Tender No: IITI(MM)/IDO/1/1A/35/SKM/2026-27

To,  
The Registrar  
Indian Institute of Technology Indore

We, \_\_\_\_\_ [name of Manufacturer], who are official manufacturers of [Insert type of goods manufactured] having factories at [insert full address of Manufacturer's factories], do hereby authorize [insert complete name of Bidder] to submit a bid the purpose of which is to provide the following goods, manufactured by us [insert name and or brief description of the goods], and to subsequently negotiate and sign the contract.

We hereby extend our full guarantee, warranty, availability of spare parts and AMC support in accordance with the Terms and Conditions of Contract with respect to the Goods offered by the above firm.

Authorized representative of the Manufacturer      Authorized representative Bidder

Signature:

Signature:

Name:

Name:

Address:

Address:

Mobile No:

Mobile No:

Email ID:

Email ID:

TENDER No.: IITI(MM)/IDO/1/1A/35/SKM/2026-27

प्रपत्र -2 / FORM-II

अमूल्यंकित तकनीकी बोली / UNPRICED TECHNICAL BID

(Bidder should provide the following details on Letter head)

TENDER NO.: IITI(MM)/IDO/1/1A/35/SKM/2026-27

Date: \_\_\_/\_\_\_/2026

Name of the Bidder \_\_\_\_\_

Sl. No.	Item Description	Qty	Make	Model	HSN Code	GST %	Country of Origin
a)	Providing & Fixing of ultra-lightweight diffusive absorptive acoustic treatment Panels in the Wall of Below balcony <b>1200X300X300MM</b>	40					
b)	Providing & Fixing of ultra-lightweight diffusive absorptive acoustic treatment Panels in the Wall of Below balcony <b>1200X450X300 MM</b>	10					
c)	Aco Providing & Fixing of ultra-lightweight diffusive absorptive acoustic treatment Panels in the Wall of Below balcony Acoustic Panels <b>1200X600X300 MM</b>	80					
d)	Providing & Fixing of ultra-lightweight diffusive absorptive acoustic treatment Panels in the Wall of Below balcony <b>1200X750X300 MM</b>	10					

\_\_\_\_\_  
(Signature of the Tenderer/Owner)

Name:

Date:

Official Seal

प्रपत्र -3 / FORM-III  
डीपीआईआईटी पंजीकरण के लिए घोषणा पत्र

Declaration for DPIIT Registration (on OEM's Letter Head)

CERTIFICATE BY BIDDER- DPIIT REGISTRATION

"I have read the clause regarding restrictions on procurement from a bidder of a country which shares a land border with India; I certify that this bidder is not from such a country or, / if from such a county, has been registered with the Competent Authority (copy of the Registration Certificate enclosed).

I hereby certify that his bidder fulfils all requirements in this regard and is eligible to be considered.

\_\_\_\_\_  
(Signature of the Tenderer/Owner)

Name:

Date:

Official Seal

प्रपत्र -4 / FORM-IV  
स्वच्छ छवि/कोई कानूनी कार्रवाई नहीं होने के संबंध में घोषणा पत्र

**DECLARATION REGARDING CLEAN TRACK/NO LEGAL ACTION**  
(to be provided on letter head of the firm)

I hereby certify that the above firm namely \_\_\_\_\_ is neither blacklisted by any Central/State Government/Public Undertaking/Institute nor any criminal case registered / pending against the firm or its owner/ partners anywhere in India preceding three years from the date of publishing of tender.

I also certify that the above information is true and correct in any every respect and in any case at a later date it is found that any details provided above are incorrect, any contract given to the above firm may be summarily terminated and the firm blacklisted.

Date:

Authorized Signatory

Place:

Name:

Designation:

Contact No.:

**प्रपत्र -5 / FORM-V**  
**बोलीदाता सूचना प्रपत्र**

**BIDDER INFORMATION FORM**

SI	Details	
1	Company Name	M/s.
2	Registration Number	
3	Manufacturer /Distributor for the quoted product	
4	Registered Address	
5	Name of Partners /Director	
6	City /Postal Code	
7	Company's Establishment Year	
8	Company's Legal Status (tick on appropriate option)	1) Limited Company 2) Undertaking 3) Joint Venture 4) Partnership 5) Others (In case of others please specify)
9	Company Category	1) Micro Unit as per MSME 2) Small Unit as per MSME 3) Medium Unit as per MSME 4) Ancillary Unit 5) SSI 6)Others (In case of Others please specify)
10	Contact Person Name : Email ID : Mobile NO. :	
11	BANK DETAILS	Name of Beneficiary : A/c. No. CC/CD/SB/OD : Name of Bank : IFSC NO. : Branch Code : Branch Address :
12	Vendor's PAN No. (Should be attached)	
13	Vendor's GST No. (Should be attached)	

प्रपत्र -6 / FORM-VI

पिछली आपूर्ति आदेश सूची प्रारूप

**PREVIOUS SUPPLY ORDERS LIST FORMAT**

Sl No.	Order placed by (Complete address of Purchaser)	Order No. and Date	Description and quantity of ordered material	Total value of order (INR)	Contact Person Name, Post, Telephone no., Email ID.
1					
2					
3					
4					
5					

**Note:** The Evaluation Committee may seek additional information from the existing users at IIT Indore or from any other Institutes, these feedbacks will be considered for technical evaluation.

\_\_\_\_\_  
(Signature of the Tenderer/Owner)

Name:

Date:

Official Seal

प्रपत्र -7 / FORM-VII  
निविदा शर्तों की स्वीकृति हेतु  
**ACCEPTANCE OF TENDER TERMS**

(To be given on Company Letter Head)

Date: \_\_\_/\_\_\_/2026

To,  
The Registrar  
Indian Institute of Technology Indore

**Sub: Acceptance of Terms & Conditions of Tender. IITI(MM)/IDO/1/1A/35/SKM/2026-27"**

**Dear Sir,**

1. I / We have downloaded / obtained the tender document(s) for the above mentioned 'Tender/Work' from the web site(s) namely: \_\_\_\_\_ as per your advertisement, given in the above mentioned website(s).
2. I / We hereby certify that I / we have read the entire terms and conditions of the tender documents from Page No. \_\_\_\_\_ to \_\_\_\_\_ (including all documents like annexure(s), schedule(s), etc), which form part of the contract agreement and I / we shall abide hereby by the terms / conditions / clauses contained therein and I have no objection for any of the content of the bid document. The rates quoted by me/us are valid and binding on me/us for acceptance till the validity of bid.
3. I / We hereby unconditionally accept the tender conditions of above-mentioned tender document(s) / corrigendum(s) in its totality / entirety.
4. I / We do hereby declare that our Firm has not been blacklisted/ debarred by any Govt. Department/Public sector undertaking.
5. I / We do hereby declare that we have quoted our firm rates inclusive of taxes if not mentioned extra.
6. I/We agree to hold this offer open until **180 days** and shall be bound to supply/commission/install/test the material and dispatch the same within the specified period.
7. **I/We agree that in case if we fail to deliver the goods/complete the work/supply within the stipulated time, then institute has full power to compound the liquidity damages or forfeit the Bid Security/Security Deposit or any necessary action as deemed fit can be taken by the IIT Indore.**
8. The articles shall be of the best quality and of the kind as per the requirement of the institution. The decision of the IIT Indore, India (herein after called the said officer) as regard to the quality and kind of article shall be final and binding on me. Should the said officer deem it necessary to change any article on being found of inferior quality, it shall be replaced by me/us free of cost in time to prevent inconvenience.
9. I/We declare that no legal/financial irregularities are pending against the proprietor/partner of the bidding firm or manufacturer.

**TENDER No.: IITI(MM)/IDO/1/1A/35/SKM/2026-27**

10. I/We undertake that the items supplied are as per Demonstration/Catalogue/technical literature description.
11. I/We undertake that the quoted rates are not higher than that approved in any other Govt. institutions in India for the same items during the current Financial Year.
12. I/we do hereby confirm that the prices/rates quoted are fixed and are at par with the prices quoted by me/us to any other Govt. of State/Central//Institute/Department/PSUs. I/we also offer to supply the material/stores at the prices and rates not exceeding those mentioned in the price bid.
13. I/We do hereby confirm that I/we aware about the provisions of "Make in India"/startup initiatives and directives regarding Price Preference Policy to Make in India Registered Bidders and I/We undertake for following the same as per directions of IIT Indore in respect of this E-Bid Enquiry.
14. I/we have necessary infrastructure for the maintenance of the material and will provide all accessories/spares as and when required.
15. I/we also declare that in case of change of Indian Agent or for any other change. Merger, dissolution solvency etc. in the organization of our foreign principles, we would take care of the Guarantee/Warranty/Maintenance of the machinery/ material t and have provided written confirmation for the same.
16. I/we undertake to get the material repaired/replace within 48 hours of the receiving of the complaint from the institute failing which a penalty of @ 1% of the cost may be recovered from the Bank Guarantee before releasing the same to us after completion period.
17. I/we undertake, If as a result of post payment audit any over payment is deducted in respect of any Supply/work done by our Agency or alleged to have been done by our Agency under this bid, it shall be recovered by the IIT Indore from our Agency.
18. I/we undertake, If any under payment is discovered, the amount shall be duly paid to our Agency by the IIT Indore.
19. I/we undertake that we shall liable to provide all the relevant records copies during the concurrency period of Contract or otherwise even after the Contract is over, whenever required by IIT Indore.

Yours Faithfully,

\_\_\_\_\_  
(Signature of the Tenderer/Owner)

Name:

Date:

Official Seal

TENDER No.: IITI(MM)/IDO/1/1A/35/SKM/2026-27

प्रपत्र -8 / FORM-VIII

वार्षिक कारोबार की घोषणा और  
इनकम टैक्स रिटर्न

**DECLARATION OF ANNUAL TURNOVER AND  
INCOME TAX RETURN**

(To be submitted on Firm/Company Letterhead)

To,

Date : \_\_\_/\_\_\_/2026

The Registrar  
Indian Institute of Technology Indore

**Sub: NIT No.- IITI(MM)/IDO/1/1A/35/SKM/2026-27**

Dear Sir,

I/we hereby declare that, our firm's Annual Turnover as follows, and I/we have also supported an Audited Accounts for your references:

F.Y. 2022-23	F.Y. 2023-24	F.Y. 2024-25

And, I/we hereby declare that, our firm had filed Income Tax Returns for last 3 years i.e. F.Y., 2022-23, 2023-24 and 2024-25. Supported by copy of ITR of three years.

\_\_\_\_\_  
(Signature of the Tenderer/Owner)

Name:

Date:

Official Seal

TENDER No.: IIT(MM)/IDO/1/1A/35/SKM/2026-27

**प्रपत्र -9 / FORM-IX**

**प्रश्न प्रारूप/ QUERY FORMAT**

(To be submitted on Firm/Company Letterhead)

Name of the Firm: \_\_\_\_\_

Contact Person: \_\_\_\_\_

Full Address: \_\_\_\_\_

Email ID: \_\_\_\_\_

Contact No.: \_\_\_\_\_

Sl. No	Reference of the Clause & Page No. of the Tender Document	Query/Clarification/ Deviation sought	Clarification/Response from IIT Indore
1			
2			
3			
4			
5			

**# Note:**

- 1) Prospective bidders are advised to submit their doubts/questions/clarifications as per Form-IX only.
- 2) No queries will be entertained after the prebid meeting.

\_\_\_\_\_  
(Signature of the Tenderer/Owner)

Name:

Date:

Official Seal

प्रपत्र -10 / FORM-X

परफॉरमेंस सिक्योरिटी प्रारूप

**ELECTRONIC-PERFORMANCE SECURITY FORMAT**

To,

.....

**WHEREAS** ..... (name and address of the supplier) (hereinafter called "the supplier") has undertaken, in pursuance of contract no. .... Dated .....to supply (description of goods and services) (hereinafter called "the contract").

**AND WHEREAS** it has been stipulated by you in the said contract that the supplier shall furnish you with a bank guarantee by a scheduled commercial bank recognized by you for the sum specified therein as security for compliance with its obligations in accordance with the contract;

**AND WHEREAS** we have agreed to give the supplier such a bank guarantee:

**NOW THEREFORE** we hereby affirm that we are guarantors and responsible to you, on behalf of the supplier, up to a total of ..... (amount of the guarantee in words and figures), and we undertake to pay you, upon your first written demand declaring the supplier to be in default under the contract and without cavil or argument, any sum or sums within the limits of (amount of guarantee) as aforesaid, without your needing to prove or to show grounds or reasons for your demand or the sum specified therein.

We further undertake to pay the Purchaser any money so demanded notwithstanding any dispute or disputes raised by the supplier(s)/vendor(s) in any suit or proceeding pending before any court or Tribunal relating thereto, our liability under this present being absolute and unequivocal. The payment so made by us under this bond shall be a valid discharge of our liability for payment there under and the supplier(s)/vendor(s) shall have no claim against us for making such payment.

We hereby waive the necessity of your demanding the said debt from the supplier before presenting us with the demand.

We further agree that no change or addition to or other modification of the terms of the contract to be performed there under or of any of the contract documents which may be made between you and the supplier shall in any way release us from any liability under this guarantee and we hereby waive notice of any such change, addition or modification.

This guarantee shall be valid until the ..... day of ....., 20.....

(Signature of the authorized officer of the Bank)

Name and designation of the officer

Seal:

Name & address of the Bank

Address of the Branch:

Phone No.:

E-mail ID:.

TENDER No.: IITI(MM)/IDO/1/1A/35/SKM/2026-27

प्रपत्र -11 / FORM-XI

**Format for Price Breakup/Financial Document**

**for**

**Providing & Fixing of "Architectural Acoustic Retrofitting Works at Nalanda Auditorium"**

**Name of the Bidder/ Bidding Firm / Company:** \_\_\_\_\_

Sl. No.	Item	Qty.	Unit Price in INR (₹)	GST in INR (₹)	Total Price in INR (₹)
a)	Providing & Fixing of ultra-lightweight diffusive absorptive acoustic treatment Panels in the Wall of Below balcony <b>1200X300X300MM</b>	40			
b)	Providing & Fixing of ultra-lightweight diffusive absorptive acoustic treatment Panels in the Wall of Below balcony <b>1200X450X300 MM</b>	10			
c)	Providing & Fixing of ultra-lightweight diffusive absorptive acoustic treatment Panels in the Wall of Below balcony Acoustic Panels <b>1200X600X300 MM</b>	80			
d)	Providing & Fixing of ultra-lightweight diffusive absorptive acoustic treatment Panels in the Wall of Below balcony <b>1200X750X300 MM</b>	10			

**Note:**

1. All Terms & Conditions will be as per NIT Document uploaded on CPPP.
2. *Format for Price Breakup (FORM-XI) must be uploaded at the time of Price bid submission only.*

\_\_\_\_\_  
(Signature of the Tenderer/Owner)

Name:

Date:

Official Seal

प्रपत्र -12 / FORM-XII  
बिक्री और समर्थन के संबंध में घोषणा

**DECLARATION REGARDING SALES AND SUPPORT**

(to be provided on letter head of the firm)

To,  
The Registrar  
Indian Institute of Technology Indore

We, M/s. \_\_\_\_\_ hereby affirm that the engineers listed below are currently employed by our organization and have consistently provided service and support in their region. We attest to their professional competence, dedication, and commitment to delivering high-quality work.

Sl. No.	Name	E-mail Id	Contact No.
1	Mr.		
2	Mr.		
3	Mr.		

We, M/s. \_\_\_\_\_ declare that we as original equipment manufacturers (OEMs) shall not be subjected to end of sale or end of support within the next five years from the date of submission of this declaration. This commitment aims to ensure the continuity and reliability of products and services provided by us, fostering stability and trust

We also certify that the above information is true and correct in every respect and in any case at a later date it is found that any details provided above are incorrect, any contract given to the above firm may be summarily terminated and the firm blacklisted.

\_\_\_\_\_  
(Signature of the Tenderer/Owner)

Name:

Date:

Official Seal

प्रपत्र -13 / FORM-XIII

**PRICE REASONABILITY CERTIFICATE**

(To be submitted on Firm/Company Letterhead)

1. I/We \_\_\_\_\_ hereby certify that the prices quoted by us in our offer letter No.....are not higher than prices to any Government Department/PSU/Institution.
2. I/We further certify that I/We have not supplied or quoted for any item in offer letter at prices lower than those quoted for the relevant items to any Government/Semi-Government/ Public/Institution within the period of 90 days preceding the last date of submission of the offer.
3. I/We hereby undertake that I/We will not supply or quote for any item in offer letter at prices lower than those quoted for the relevant items to any Government/Semi-Government/ Public/ Institution/ within the period of validity of the offer.
4. I/We also undertake to bring the attention of the Authorities, any incidence of breach of any of the above paras within 30 days from the occurrence of the breach and further undertake to refund/reimburse the difference which may arise due to breach of any of the above paras and I/We also understand that the decision of Authorities, regards to the determination of quantum payable shall be final.

\_\_\_\_\_  
(Signature of the Tenderer/Owner)

Name:

Date:

Official Seal

## TECHNICAL SPECIFICATIONS COMPLIANCE SHEET

1. The technical compliance bid must be in this sheet only, otherwise, it should be assumed that the bidder is not able to offer a technically desired product. Information provided elsewhere or in different form will not be considered.
2. All the columns of this sheet should be filled in compulsorily by the bidder, merely asking the office to refer catalogue or brochure will not be entertained.
3. The bidder shall assume full responsibility of the information provided in this sheet. Any false statement should render the breach of basic foundation of the tender.

S. No.	Technical specification	Features available write (Yes/No)	Offered Specification	Any deviation from specification	Remarks
1	Providing & Fixing of ultra-lightweight diffusive absorptive acoustic treatment Panels in the Wall of Below balcony <b>1200X300X300MM</b>				
2	Providing & Fixing of ultra-lightweight diffusive absorptive acoustic treatment Panels in the Wall of Below balcony <b>1200X450X300 MM</b>				
3	Providing & Fixing of ultra-lightweight diffusive absorptive acoustic treatment Panels in the Wall of Below balcony Acoustic Panels <b>1200X600X300 MM</b>				
4	Providing & Fixing of ultra-lightweight diffusive absorptive acoustic treatment Panels in the Wall of Below balcony <b>1200X750X300 MM</b>				

**Note:** Bidder should submit with Technical Specification Compliance Sheet with Technical Specification Bid.

\_\_\_\_\_  
(Signature of the Tenderer/Owner)

Name:

Date:

Official Seal

**प्रपत्र -15 / FORM-XV**

(To be submitted on Firm/Company Letterhead)

**UNDERTAKING**

I/We hereby declared that all the Test Reports compliances as per Standard Specifications mentioned in the NIT Document No: \_\_\_\_\_ for "Providing & Fixing of \_\_\_\_\_" will be submitted by us, if required/asked.

Further, we will provide all Statuary valid Certificates/Permissions/License/Hardware/Software as required for smooth running of the supplied material including all essential requirements for installation/fixing etc.

Furthermore, I/We hereby declare that, our quoted prices against this E-Bid Enquiry are not higher than prices offered by us to any others Govt. Institutions/Other Institutions/Departments as per prevailing market prices and we are liable for passing of all the benefits of GST in terms of cost reduction on account of various tax factors to IIT Indore as per the provisions of GST Act 2017. If any time IIT Indore will get the information that we have supplied items on higher prices in comparison to other institutes on the basis of prevailing applicable prices, we are undertaking that, we are liable for refunding and depositing back such difference amount to IIT Indore from our side without any question.

I/We are also undertaken that the Department of Commerce or Ministry/any other Department has been not debarred/blacklisted our firm as per best of our knowledge, if any such debarment/blacklisting come to the notice of IIT Indore Authorities during execution of Supplies against this E-Bid Enquiry, Indore have right to reject our proposal and take appropriate action deemed fit against our firm as per prevailing applicable Rules & Regulations.

\_\_\_\_\_  
(Signature of the Tenderer/Owner)

Name:

Date:

Official Seal

# Balcony Front: DAC Edge - Diffusive absorptive acoustic panel

**TYPE A** - 750 WIDTH - 750mm X 1200mm X 300mm

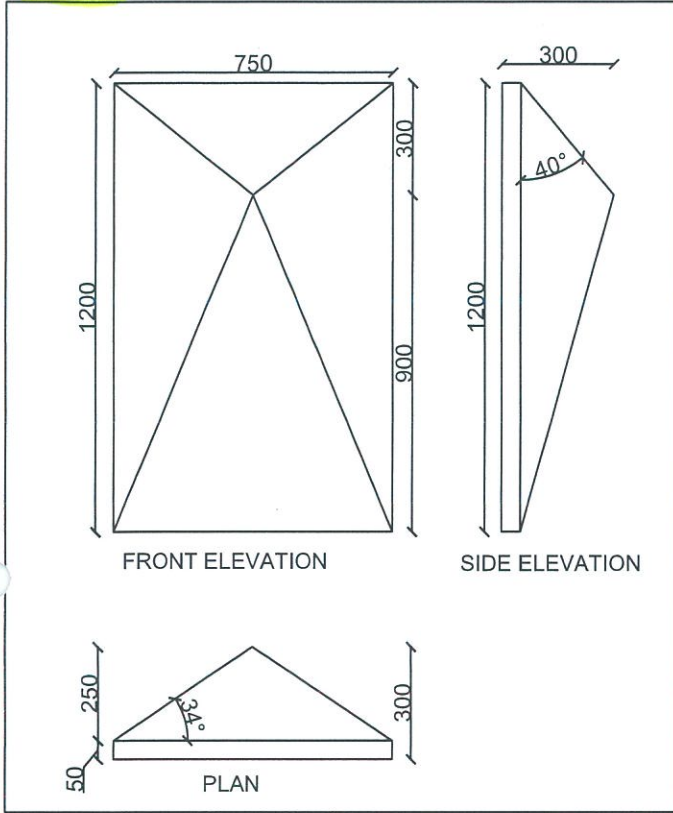

**TYPE B** - 600 WIDTH - 600mm X 1200mm X 300mm

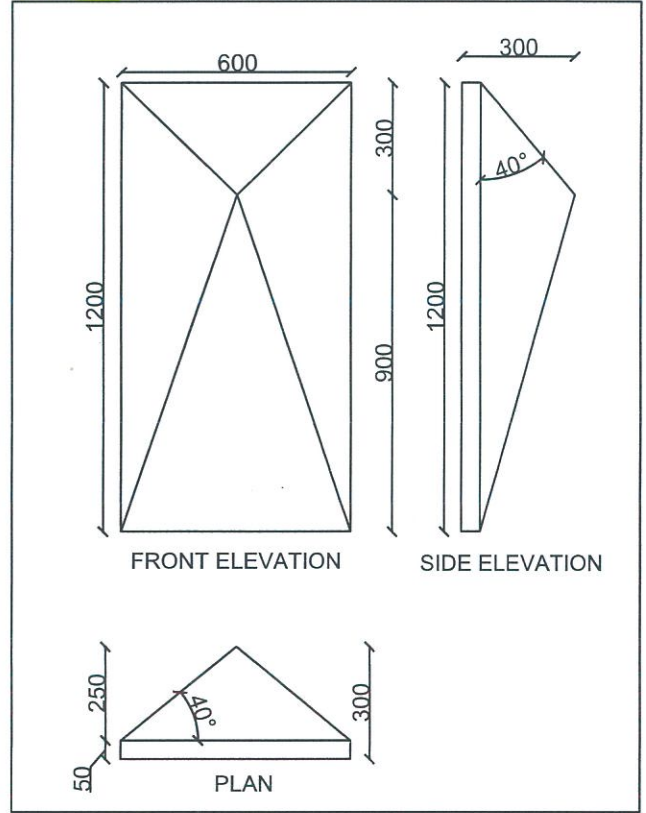

**TYPE C** - 450 WIDTH - 450mm X 1200mm X 300mm

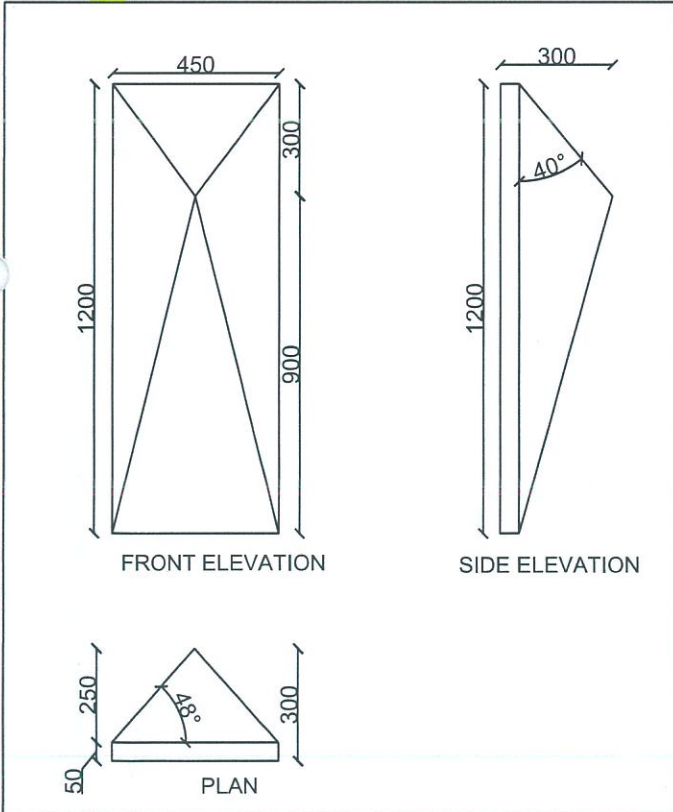

**TYPE D** - 300 WIDTH - 300mm X 1200mm X 300mm

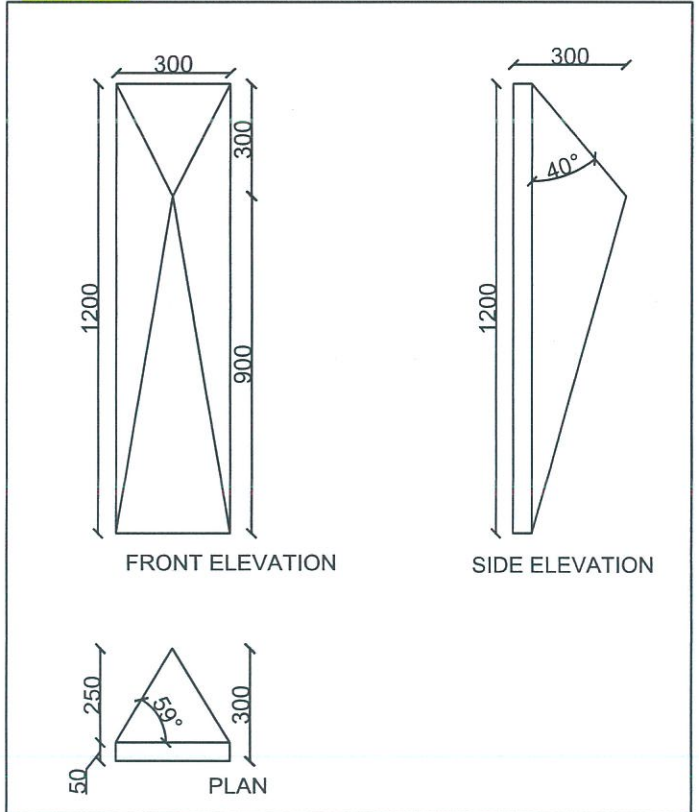

Annexure-II

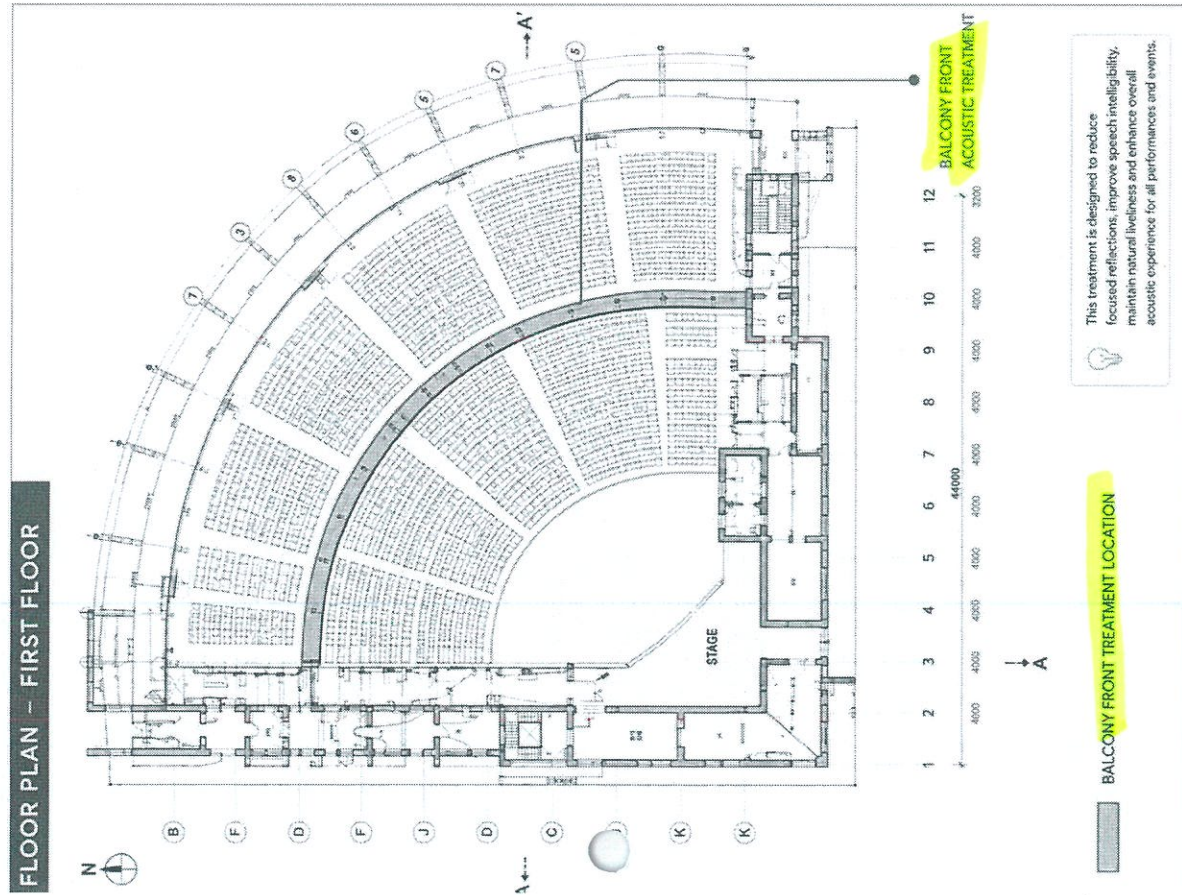

**BALCONY FRONT - DIFFUSIVE ABSORPTIVE PANELS**  
Conceptual image

**REFERENCE - SINGLE PANEL (TYPICAL)**  
FRONT ELEVATION

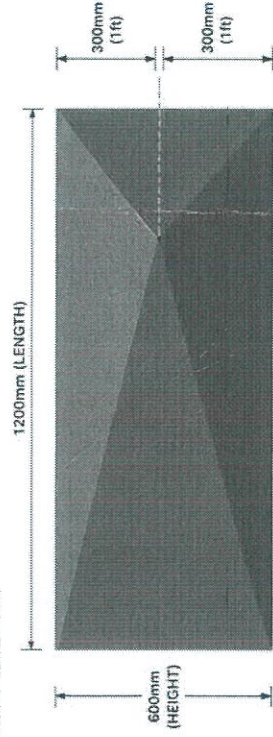

**PROJECT : Nalanda Auditorium IIT- INDORE**